

# SWB-2

## SPEAKER WALL BRACKET

### FEATURES:

- FLEXIBLE MOUNTING PRODUCT THAT WILL SATISFY MOST SIMPLE REQUIREMENTS
- SWB-2 HOLDS UP TO 4.4Kg (10 LBS)
- ALL STEEL CONSTRUCTION, BLACK PAINTED FINISH.
- PACKED AND SOLD AS PAIRS.

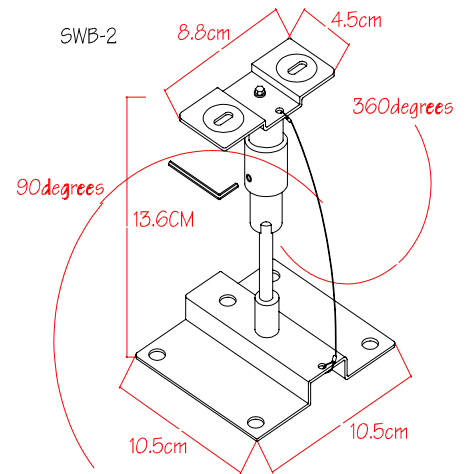

SWB-2

### SPECIFICATIONS:

The SWB-2 is designed to be used as multi-purpose speaker brackets. This product is made from steel, and have an attractive black painted finish. The SWB-2 is suggested for mounting mini-speaker applications. This bracket pair can be used for many other application as well. We recommend that the load limit and physical restrictions of each bracket be observed.

## ARCHITECT'S AND ENGINEER'S SPECIFICATIONS

### MODEL SWB-2

The SWB-2 is a multi-tilt mini-speaker type bracket. If this bracket is used on standard mini speakers, then the pair of brackets can be used to support two mini-speakers. The SWB-2 is an all steel bracket, with a painted black finish. Some assembly is required. The SWB-2 comes standard equipped with a security wire. The maximum weight limit on this bracket is 4.4Kg (10Lbs.). This bracket is very flexible. It will swivel left and right, tilt up and down, and also allows for some rotation. Wall plate mounting dimentions are 8.0cm high, 8.0cm wide, 4 mounting holes total, 0.6cm hole size. Speaker mounting plate has 5.9cm mounting centers, two holes total, the oblong holes are 1.4 x 0.6 cm.