



Clever Features, Contractor Friendly

AMIS26

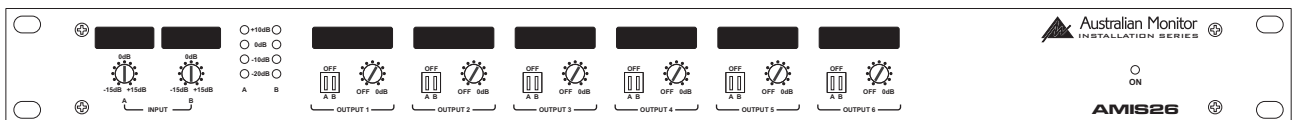

2 Input, 6 Output Distribution Amplifier

Installation & Operation Manual



AUS, EUR, USA
Copyright 3rd Dec 2003
Rev A: 3rd Dec 2003

Internal Revision Info
Rev 1 24/11/03
Rev 2 28/11/03
Rev 3 02/12/03

 <p>CAUTION RISK OF ELECTRIC SHOCK DO NOT OPEN</p> <p>CAUTION: TO REDUCE THE RISK OF ELECTRIC SHOCK. DO NOT REMOVE COVER (OR BACK). NO USER-SERVICEABLE PARTS INSIDE. REFER SERVICING TO QUALIFIED SERVICE PERSONNEL.</p>	 <p>This symbol is intended to alert the user to the presence of uninsulated "dangerous voltage" within the product's enclosure that may be of sufficient magnitude to constitute a risk of electric shock to persons.</p>
<p>WARNING ! TO REDUCE THE RISK OF FIRE OR ELECTRIC SHOCK. DO NOT EXPOSE THIS EQUIPMENT TO RAIN OR MOISTURE.</p>	 <p>This symbol is intended to alert the user to the presence of important operation and maintenance (servicing) instructions in the literature accompanying the appliance.</p> <p>Caution: To prevent electric shock do not use this (polarized) plug with an extension cord, receptacle or other outlet unless the blades can be fully inserted to prevent blade exposure.</p> <p>To prevent electric shock, match wide blade of plug to wide slot, fully insert.</p>

CONTENTS

	Page
1. Introduction	4
2. Front Panel	5
3. Back Panel	6
4. Internal Adjustment	7
5. Block Diagram	9
6. Dimensions	10
7. Specifications	11

1. INTRODUCTION

The Australian Monitor Installation Series AMIS26 is a high quality 2 input, 6 output distribution amplifier. The AMIS26's 2 inputs can be balanced or unbalanced and each input's sensitivity can be switched between Mic and Line level. 24 VDC Phantom power is individually switchable per input and for ease of setup, a four segment LED level meter is provided per input. Each of the AMIS26's inputs is individually assignable to any of the 6 outputs via front panel DIP switches. Outputs can be balanced or unbalanced and feature up to 30dB of attenuation, so they can be run as any combination of line level or mic level outputs. Ample label space is provided for both inputs and outputs and the AMIS26 is powered via a supplied 24VDC power supply. The AMIS26 provides a low noise, feature packed, signal routing solution to cover a wide range of installation needs at a contractor friendly price.

2. FRONT PANEL

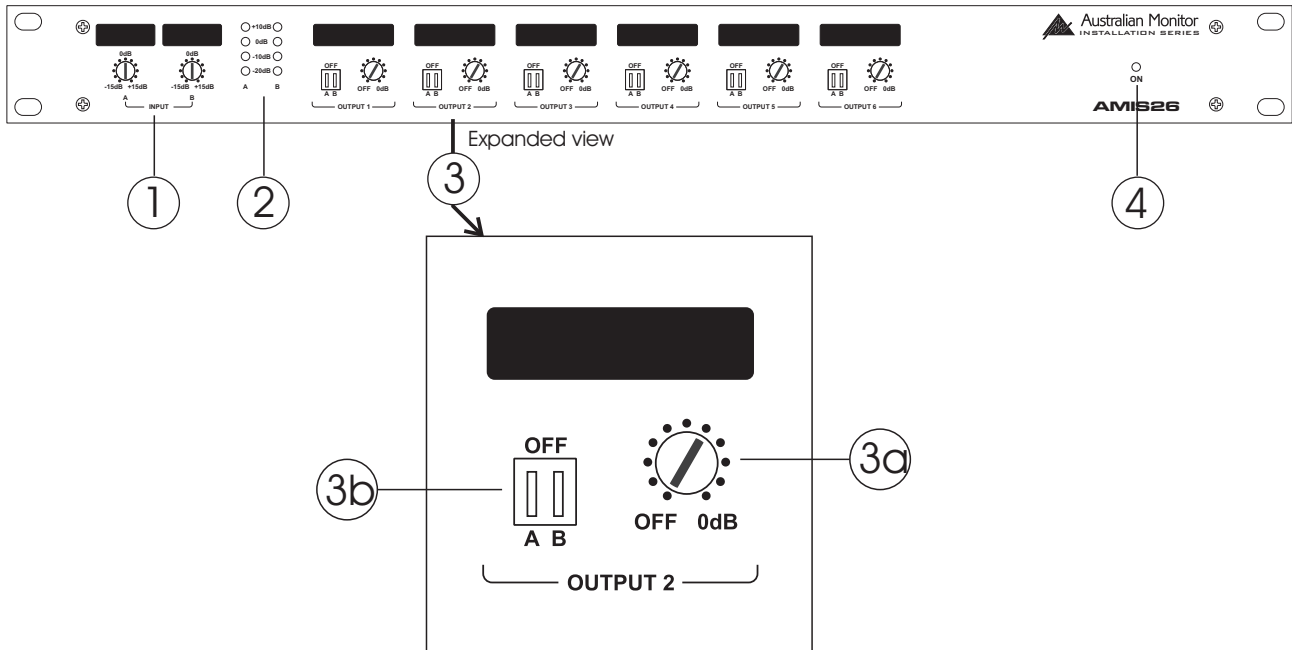

1. INPUT LEVEL CONTROL(S)

The input level controls are screwdriver adjustable trim pots. The input level controls can boost or cut the input signal by up to 15dB.

2. LEVEL METER

These 4 segment LED meters show the strength of each of the AMIS26's input signals. LED segments are calibrated to the following level markings and show the following colours:

- -20dBu (green)
- -10dBu (green)
- 0dBu (yellow)
- +10dBu (red)

3. OUTPUT SECTION

3a. OUTPUT LEVEL CONTROLS

The output level controls are screwdriver adjustable trim pots. These level controls attenuate the output level, with a range from -60dB at 'Minimum' position to 0dB at 'Maximum' position.

3b. INPUT ASSIGN SWITCHES

These recessed DIP switches assign input A and input B to a desired output.

4. POWER LED

This blue LED indicates the unit is powered "on".

3. BACK PANEL

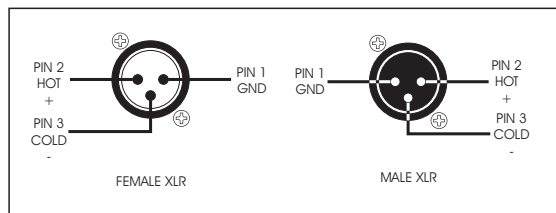
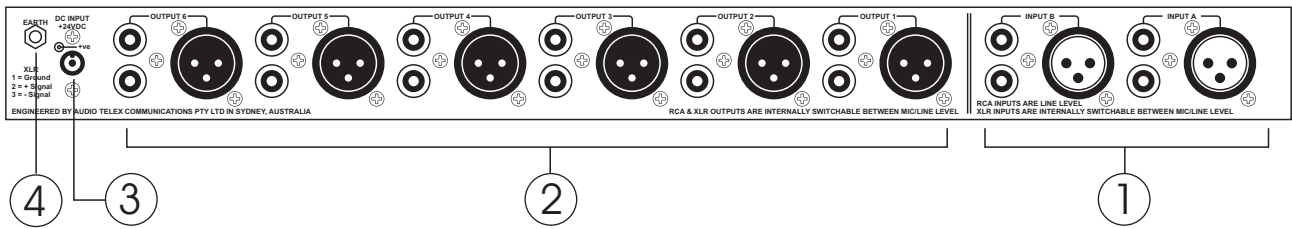

1. INPUT A/B CONNECTORS

The balanced XLR inputs can be used as Mic or Line level inputs and are switched between input sensitivities via internal DIP switches accessed through the lid (see internal adjustments section page 7). The dual RCA inputs are Line level inputs only and are internally summed to mono.

2. OUTPUT CONNECTORS

The AMIS26's outputs can be either balanced XLR or unbalanced dual RCA's. Both these outputs can be switched between Mic level & Line level via internal DIP switches accessed through the lid (see internal adjustments section page 7).

3. 24VDC POWER CONNECTOR

This 2.1 mm connector accepts power from the provided 24VDC power supply.

4. EARTH Stud

In some circumstances it may be necessary to ground the unit to eliminate noise in the system. This can be done by using this earth stud.

NOTE: This stud provides a connection to chassis ground. Audio ground is internally tied to chassis ground.

4. INTERNAL ADJUSTMENT



NOTE: The following adjustments involve access to the inside of the AMIS26 and should only be attempted by a qualified technician. All internal adjustments are accessible through the lid of the AMIS26. Always turn off the DC power and remove the DC power cord before accessing the inside of the AMIS26.

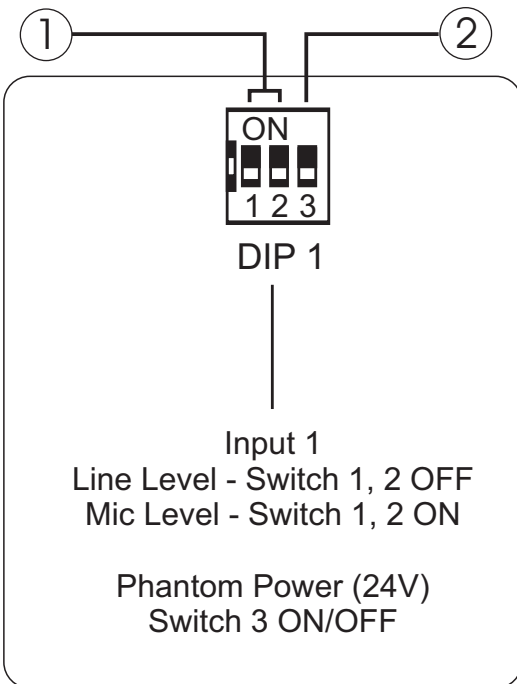
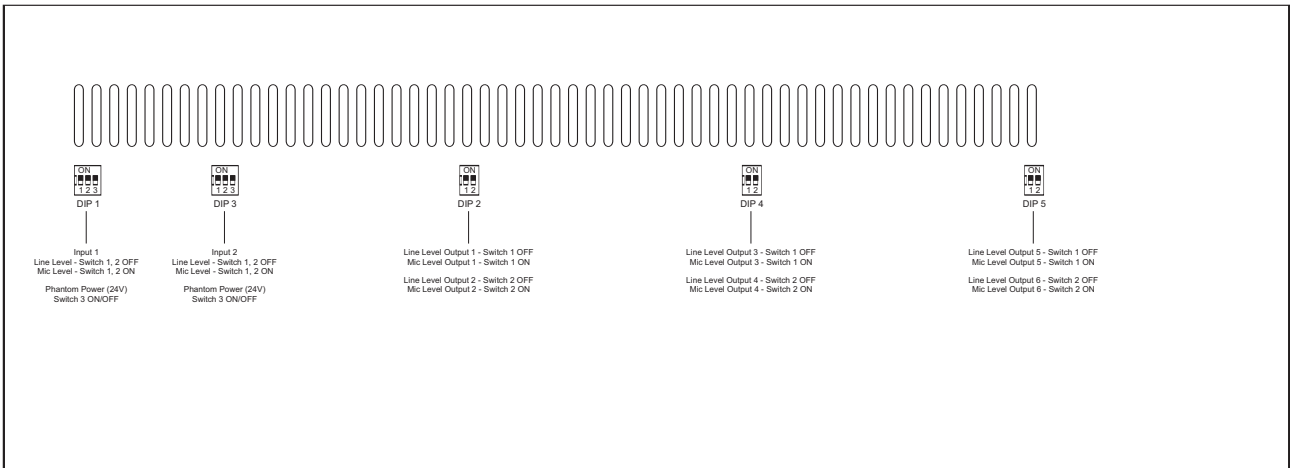

1. Input Sensitivity DIP Switches. DIP 1 (INPUT A), DIP 3 (INPUT B) Switches 1, 2

Switches 1 and 2 on this 3 pole DIP switch when selected to the "on" position will switch the balanced XLR input to Mic level. The "off" position will switch the balanced XLR input to Line level. The Default setting is Line level.

NOTE: This switch does not effect the sensitivity of the unbalanced dual RCA input.

2. Phantom Power Switch. DIP 1 (INPUT A), DIP 3 (INPUT B) Switch 3

This switch will enable 24VDC phantom power to the desired input. The default setting is "off".

NOTE: Before switching Phantom power on please ensure that no line level source equipment is connected to the effected input.

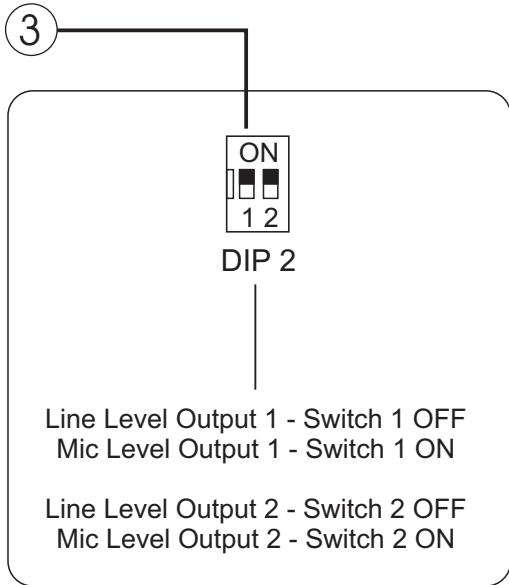

3. **Output Level DIP switch.**
DIP 2 Switch 1 (OUTPUT 1)
DIP 2 Switch 2 (OUTPUT 2)
DIP 4 Switch 1 (OUTPUT 3)
DIP 4 Switch 2 (OUTPUT 4)
DIP 5 Switch 1 (OUTPUT 5)
DIP 5 Switch 2 (OUTPUT 6)

This switch will change the output sensitivity of the desired output from Mic to Line level. When the switch is "on" the output level will be switched to Mic level.

NOTE: This switch effects both balanced XLR & dual RCA outputs.

5. BLOCK DIAGRAM

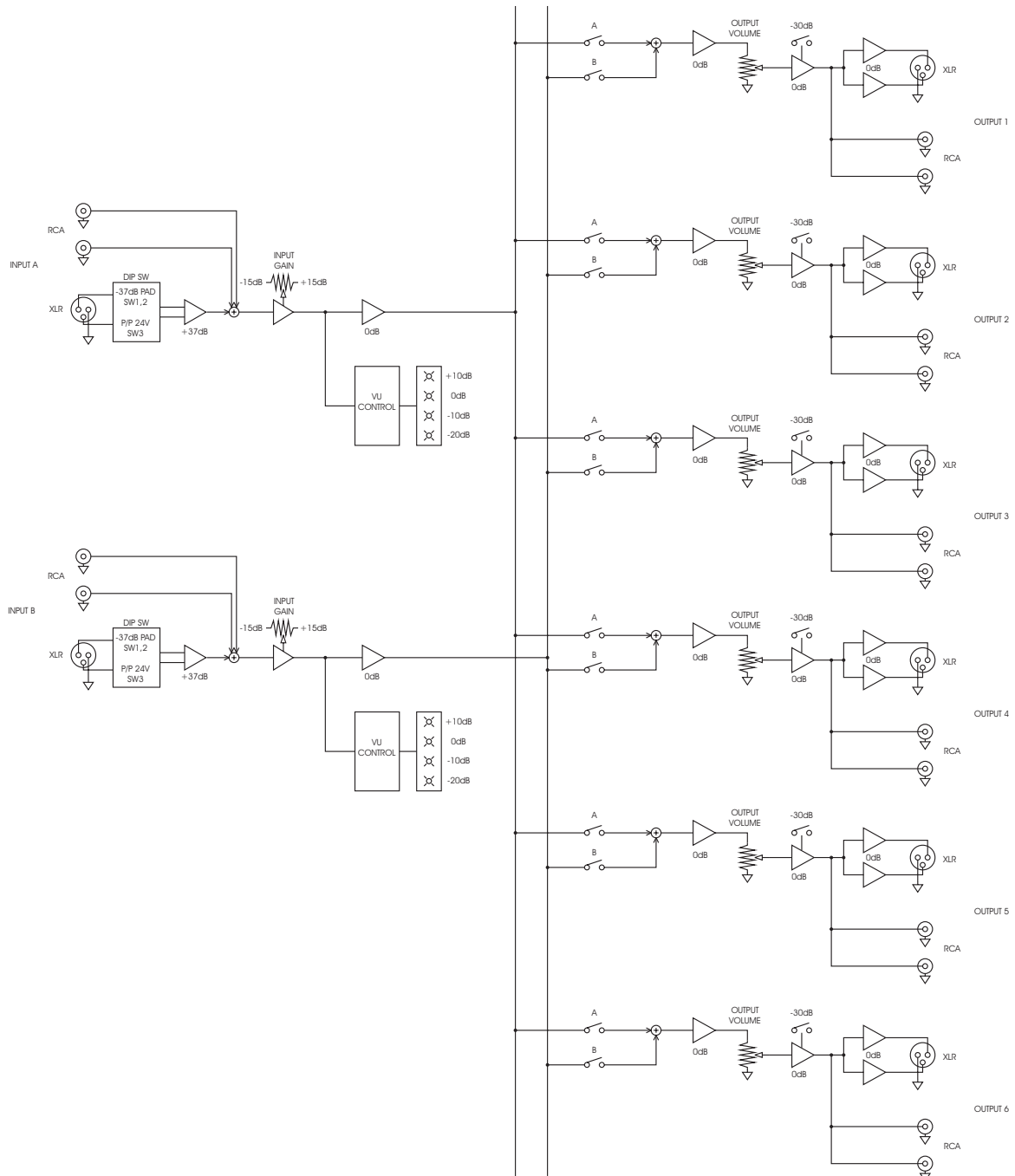

6. DIMENSIONS

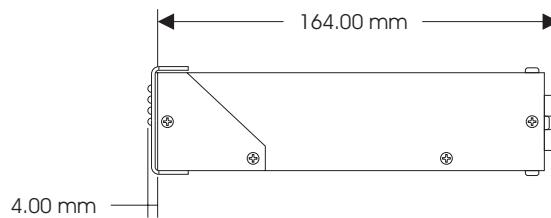
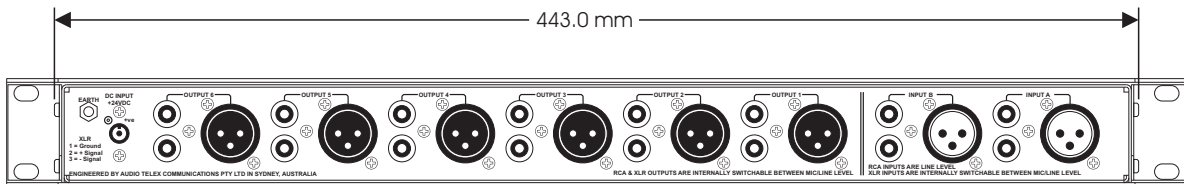
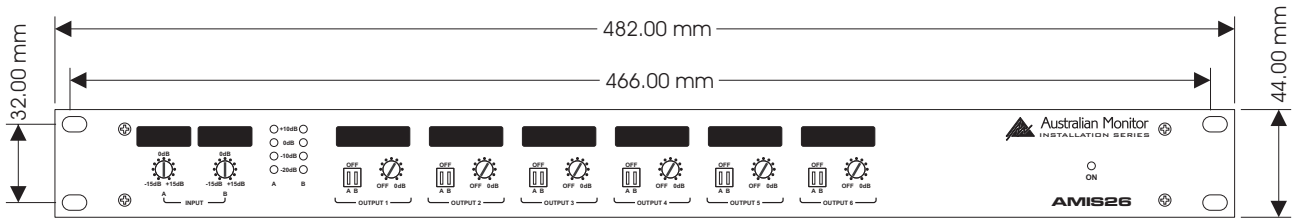

7. SPECIFICATIONS

-Dimensions:	44.0 x 482.0 x 168.0 (HxWxD) mm
-Weight:	Net 2.5kg Shipping 3.0kg Net 5.5lb Shipping 6.6lb
-Power Input:	24VDC (regulated) 12VA max
-Sensitivity:	Line (XLR) 775mV (0dB) Mic (XLR) 10mV (-37dB) Line (RCA) 775mV (0dB)
-Output Mic/Line Gain switch:	28dB
-Frequency Response: (0dB/-3dB)	10Hz - 50kHz
-THD:	Line In (XLR/RCA) 0.02% Mic In (XLR) 0.1%
-Noise:	-89dB
-Crosstalk:	Better than 80dB
-Phantom Power:	24VDC

All measurements referenced to 0dBu (0.775mV)
All measurements done with levels set In/Out at 0dB

AUSTRALIA and NEW ZEALAND

www.australianmonitor.com.au

Sydney

(NSW & ACT Sales)

Private Bag 149, Silverwater NSW 1811
149 Beaconsfield Street, Silverwater NSW 2128
Ph: (02) 9647 1411
Fax: (02) 9648 3698
E-mail: nsw@audiotelx.com.au

Brisbane

(Qld Sales)

P.O. Box 871, Fortitude Valley QLD 4006
42 Commercial Road, Fortitude Valley QLD 4006
Ph: (07) 3852 1312
Fax: (07) 3252 1237
E-mail: qld@audiotelx.com.au

Perth

(WA Sales)

P.O. Box 404, North Perth WA 6906
299 Fitzgerald Street, West Perth WA 6005
Ph: (08) 9228 4222
Fax: (08) 9228 4233
E-mail: wa@audiotelx.com.au

Melbourne

(Vic & Tas Sales)

P.O. Box 151, Blackburn South VIC 3130
22/277 Middleborough Road, Box Hill VIC 3128
Ph: (03) 9890 7477
Fax: (03) 9890 7977
E-mail: vic@audiotelx.com.au

Adelaide

(SA & NT Sales)

P.O. Box 157, Hindmarsh SA 5001
31 Walsh Street, Thebarton SA 5031
Ph: (08) 8352 4444
Fax: (08) 8352 4488
E-mail: sa@audiotelx.com.au

Auckland

(NZ Sales)

P.O. Box 512, Albany 1331
Unit B, 11 Piermark Drive, Albany 1331
Ph: (09) 415 9426
Fax: (09) 415 9894
E-mail: audiotlx@nznet.gen.nz

EUROPE/ASIA/MIDDLE EAST

www.australianmonitor.com.au

International Sales

Private Bag 149, Silverwater NSW 1811
149 Beaconsfield Street, Silverwater NSW 2128
Australia
Ph: 61-2- 9647 1411
Fax: 61-2-9748 2537
E-mail: international@audiotelx.com.au

USA/CANADA/SOUTH AMERICA

www.australianmonitor.com

Australian Monitor Audio Inc.

PO Box 3126, Lynnwood, WA 98046
Ph: 425 673 5175
Fax: 425 673 7825
E-mail: sales@australianmonitor.com

