



SE45 Series

SE45 Series
Square Acoustic Back-Box for 4-5"
Loudspeakers

FEATURES

- Rust resistant heavy gauge electro-plated steel
- Powder coated white
- Designed to be compact and fit AEG G72W baffle only.
- Model is approved for ULC™ Listed Installations
- Surface mounting only



SE45 Series

Square Acoustic Back-Box for 4-5" Loudspeakers

SE45 Series

SPECIFICATIONS

Baffles that work with these back-boxes:

Standard Screw Mount:
G72W
Torsion Mount:
N/A

Note: k/o's are 1-1/4" centered from the back on 2 sides at 180 degrees from each other.
Back-box can be custom configured, send us a drawing or sketch and we would be pleased to quote you.
In order to fulfill ULC listing requirements, this back box must be installed with an Arnscoff Fire Rated Speaker.

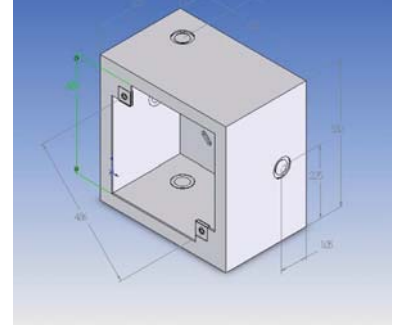

Model No.	Depth	Lined	Spray Dampened	Cubic Feet	Mounting	ULC Listed
Screw Mount:						
SE45W	3.5"	No	No	0.06	N/A	Yes

ARCHITECTS AND ENGINEERS SPECIFICATIONS

MODELS SE45W (Surface Mount)

The ceiling backbox shall be AEG Model SE45W. The backbox shall be constructed of heavy gauge steel and shall be painted with white powder paint. Combination 1/2" - 3/4" knockouts for conduit shall be provided. The unit shall measure 14cm (5 1/2") square, and have a maximum depth of 8.9cm (3.5"). This unit shall be used wherever surface ceiling or wall mount conditions exist. This unit can be mounted directly onto concrete. This unit has the back completely closed, allowing the containment of wiring and is equipped with a ground screw. This unit is U.L.C. approved for use with a voice fire alarm system. The backbox shall accommodate AEG baffle Model G72W.
ULC is a Trademark of Underwriters Laboratories of Canada